

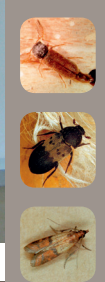

Altarion® - Nitrogen Fumigation Chamber



Features

- Non-toxic method
- Robust gastight chamber
- Microprocessor-regulated climate control
- No more gas cylinders! Nitrogen is produced on-site from air!
- Simple handling and operation
- Could be used as air-conditioned chamber for quarantine

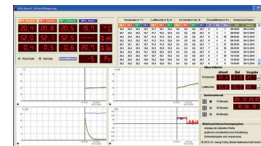

Sketch of the Nitrogen Chamber

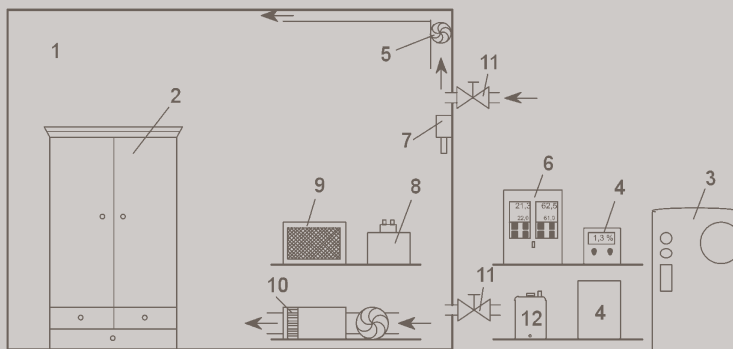

- 1 Gastight chamber
- 2 Infested artefacts
- 3 Nitrogen generator
- 4 Oxygen-monitoring
- 5 Ventilation
- 6 Climate controller with
- 7 Humidity sensor
- 8 Humidifier
- 9 Dessicator
- 10 PTC-heating system
- 11 Shutter for ventilation
- 12 Water reservoir with pump

Mains Plug 230 V/16 A/50 Hz

Ventilation system into environment available (windows or openings in the walls of the structure/facility necessary).

Technical subject to change

BINKER Materialschutz GmbH

Westendstrasse 3
D - 91207 Lauf a. d. Pegnitz

Telefon: +49 (0)9123 99820
Telefax: +49 (0)9123 998222
E-Mail: info@binker.de

Internet: www.binker.de

